

Multifunctional regulator E16L-14V – Replaces Mitsubishi

Feature overview

- FULLY MONOLITHIC DESIGN
- LOW SIDE FIELD DRIVER
- THERMAL PROTECTION
- FIELD SHORT CIRCUIT PROTECTION
- PROTECTED DIAGNOSTIC LAMP DRIVER
- PROTECTED HIGH SIDE RELAY DRIVER
- COMPLEX DIAGNOSTICS
- LOAD RESPONSE CONTROL
- DFM OUTPUT (FIELD MONITOR)

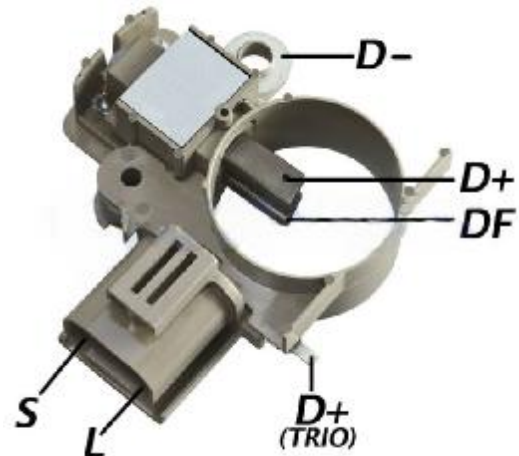

E16L-14V Replaces Mitsubishi

Original code
number:

A866X09171, A866X09170, MD611481

Application:

Mitsubishi : Pajero 2500 Diesel, Delica 2300 Van Diesel, Mirage 1800 Diesel, Galant 1800 Diesel, Sava 1800 Diesel, Shariot 1800 Diesel.

Alternator:

mitsubishi: A3T75883, A3TN5188, A3TN5288, ME017614

Description

The E16L-14V is a monolithic multifunction alternator voltage regulator intended for use in automotive application. It includes the control section, the field power stage, fault diagnostic circuit which drives a warning lamp.

Multifunctional regulator E16L-14V – Replaces Mitsubishi

Application diagram

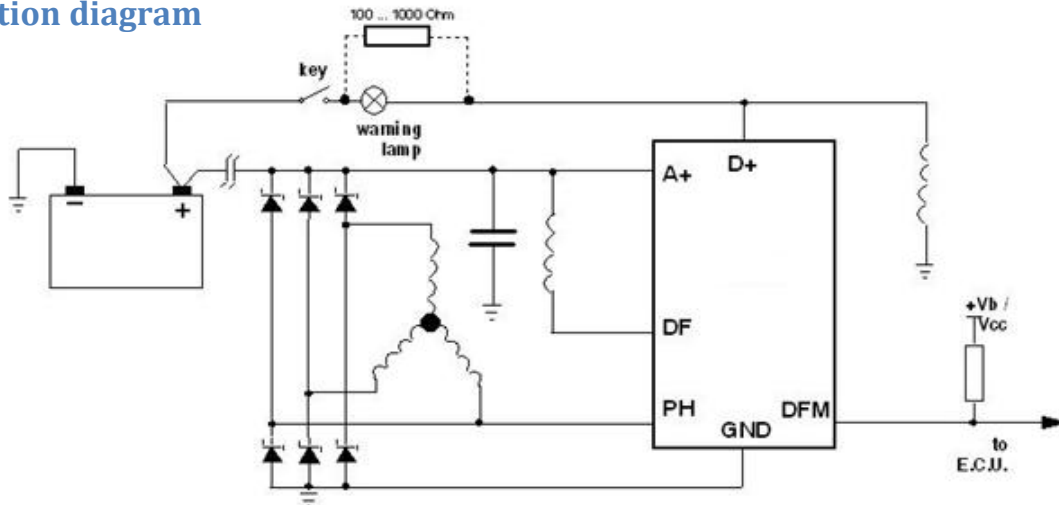

Electrical characteristics

Absolute maximum ratings

Symbol	Parameter	Value	Unit
VS	DC Supply Voltage (2 min. @ 25°)	24	V
	Transient Supply Voltage (load dump); $t < 0.5s$ @ 25°C	40	V
	Transient Supply Voltage (low energy spikes pulse ISO7637/1)	60	V
IO	Output Current Capability	internally limited	A
Ptot	Power Dissipation(@ Tcase = 150°C, I _{field} = 5A)	Tbd	
	Reverse Voltage all pins @ 25°C, T = 15s	-2.5	V
	DC Pin Current (bonding limitation) on DF, A+, GND pins	11	A
	EDS Voltage (Human body model)	±4	KV

Thermal data

Symbol	Parameter	Value	Unit
T _{case}	Case temperature	-40 to 160	°C
T _{stg}	Storage temperature	-40 to 170	°C
T _{sh}	Thermal shutdown	185 ±15	°C
R _{th j-case}	Thermal Resistance Junction-case Max.	1.5	°C/W

Electrical specifications

(- 40 °C ≤ T_J ≤ 125 °C, unless otherwise noted)

Multifunctional regulator E16L-14V – Replaces Mitsubishi

Symbol	Parameter	Test Condition	Min.	Typ.	Max.	Unit
V _{bat}	Operating Supply Voltage		8.5		18	V
I _{bsink}	Supply Battery Current				50	mA
I _{bstby}	Stand-by Current	V _{bat} = 12V, T = 25°C			300	μA
		V _{bat} = 12V, T = 40°C			500	
V _{reg}	Regulated Voltage & Therm. Drift (standard version)	I _{alt} = 0.5 · I _{nom} ; rpm = 0.5 · RPMMAX; T = 20°C	14.3 -4	14.45 -3	14.6 -2	V mV/°C
V _{reg} ⁽¹⁾	Regulated Voltage & Therm. Drift (optional version)	I _{alt} = 0.2 · I _{nom} ; rpm = 0.5 · RPMMAX; T = 20°C	14.1 -11.5	14.5 -10	14.9 -8.5	V mV/°C
f _{sw}	Switching Frequency	in FSDF	30		400	Hz
V _{rpm}	Delta V _{rpm}	1800 < rpm < 12000; I _{alt} = 0.3 · I _{nom}			200	mV
V _{load}	Delta V _{load}	0.1 · I _{nom} < I _{alt} < 0.9 · I _{nom} ; rpm = 0.5 · rpm _{max}			200	mV
V _{reg}	Reg. Voltage without Battery	I _{alt} = 3A resistive			16	V
V _{OV}	D+ Drivers Disable Thershold	Voltage on pin A+ to have D+ = OFF	18		22	V
T _{j-sd}	Thermal Shut-down	DF = OFF STATE D+ = OFF STATE	170		200	°C
T _{j-sd-hys}	Thermal Shut-down Hysteresis	DF, D+ = from off state (due to thermal shutdown) to on	2		10	°C
R _{on}	Low Side Driver R _{dson}	T = 150°C; I = 5A			230	mΩ
R _{on}	Low Side Driver R _{dson}	T = 25°C; I = 5A			130	mΩ
V _F	Freewheeling Diode DF	I _F = 5A			2	V
I _{fSC}	Short Circuit Threshold DF	DF = 12V; T = -40 to 25°C	8.5		18	A
I _{fSC}	Short Circuit Threshold DF	DF = 12V; T = 25 to 125°C	7		18	A
V _{s1}	Output Short to GROUND Threshold DF		2.1		3.9	V
FSDF	Pre-excitation F.S.D.F	f = 348Hz ±15%	10.62	12.5	14.38	%

Multifunctional regulator E16L-14V – Replaces Mitsubishi

Symbol	Parameter	Test Condition	Min.	Typ.	Max.	Unit
t_{ST}	Soft Start Delay Time	activated at first running-on only		0		s
t_{SL}	Soft Attack Time	from 0 to 100% field duty cycle	2.5	2.88	3.39	s
BI	Soft Attack Blind Zone	% of maximum D.C. immediate variation of soft attack	0		10	%
t_{rise}	Output Voltage Rise Time	$I_{field} = 3A$ resistive	5		50	μs
t_{fall}	Output Voltage Fall Time		5		50	μs
I_{fk}	Output Field Driver Leakage Current	DF = 24V			1	mA
V_{HS}	High Side Driver Saturation Voltage	$I_{source} = 1A$			1.2	V
V_{LS}	Low Side Driver Saturation Voltage	$I_{sink} = 0.25A$			1.5	V
VLSB	Selfbias without supply lamp driver voltage				4	V
IHSC	High Side Current Limitation	A+ = 17.5V; D+ = GND	1.2		3	A
ILSC	Low Side Current Limitation	A+ = D+ = 17.5V	0.45		1.5	A
V_{thD+}	Enable Regulator Voltage D+		0.8	1	1.15	V
I_{thD+}	Enable Regulator Pull-down Current		0.4		3.5	mA
DISAB	Soft Attack Inhibition Frequency		265	313	360	Hz
EN ₁	Soft start delay time enable frequency		88	104	120	Hz
EN _{1_hy}	Soft start delay time enable frequency hysteresis		EN ₁ -8	EN ₁ -10	EN ₁ -12	Hz
VPHL1	Enable Control Voltage PH high threshold	Square wave 1KHz	0.67	0.795	0.92	V
VPHL2	Enable Control Voltage PH low threshold		VPHL1 -0.48	VPHL1 -0.57	VPHL1 -0.66	V
t_{PH}	PH Filtering Time		15		120	μs
VPHH1	Diag. Phase Loss High Voltage		9	10.25	11.5	V
VPHH2	Diag. Phase Loss Low Voltage		4	5	6	V
t_{PHD}	Diagnostic PH Filtering Time		50		200	μs
I_{PH}	Phase Pull-down Current		1		8	mA
t_D	Diagnostic Alarm Delay		0.48	0.575	0.65	s
f_{DFM}	DFM Open Drain Switching Frequency	in FSDF	30		400	Hz
V_{ol}	Output Low Voltage DFM	$I_{sink} = 25mA$			1.5	V

Multifunctional regulator E16L-14V – Replaces Mitsubishi

Symbol	Parameter	Test Condition	Min.	Typ.	Max.	Unit
I_{dfmt}	Short Circuit Protection DFM	VDF_MON = 12V	25		200	mA
I_{lk}	Output Leakage Current DFM	VDF_MON = 24V			0.1	mA
t_{TM}	DFM Output Voltage rise time	R = 2.7k Ω ; C = 1nF; V _{alim} = 13.5V	0.05		50	μ s
T_TD	DFM Output Voltage fall time	R = 2.7k Ω ; C = 1nF; V _{alim} = 13.5V	0.05		50	μ s

(1) Available through a metal option of the actual device.

Thermal compensation

Temperature (°C)	Vreg (V)		
	Min.	Typ.	Max.
-40	14.43	14.645	14.86
25	14.30	14.45	14.60
125	13.90	14.15	14.40

